

2. SCHEMATIC DIAGRAM — MAIN SECTION (1/3) —

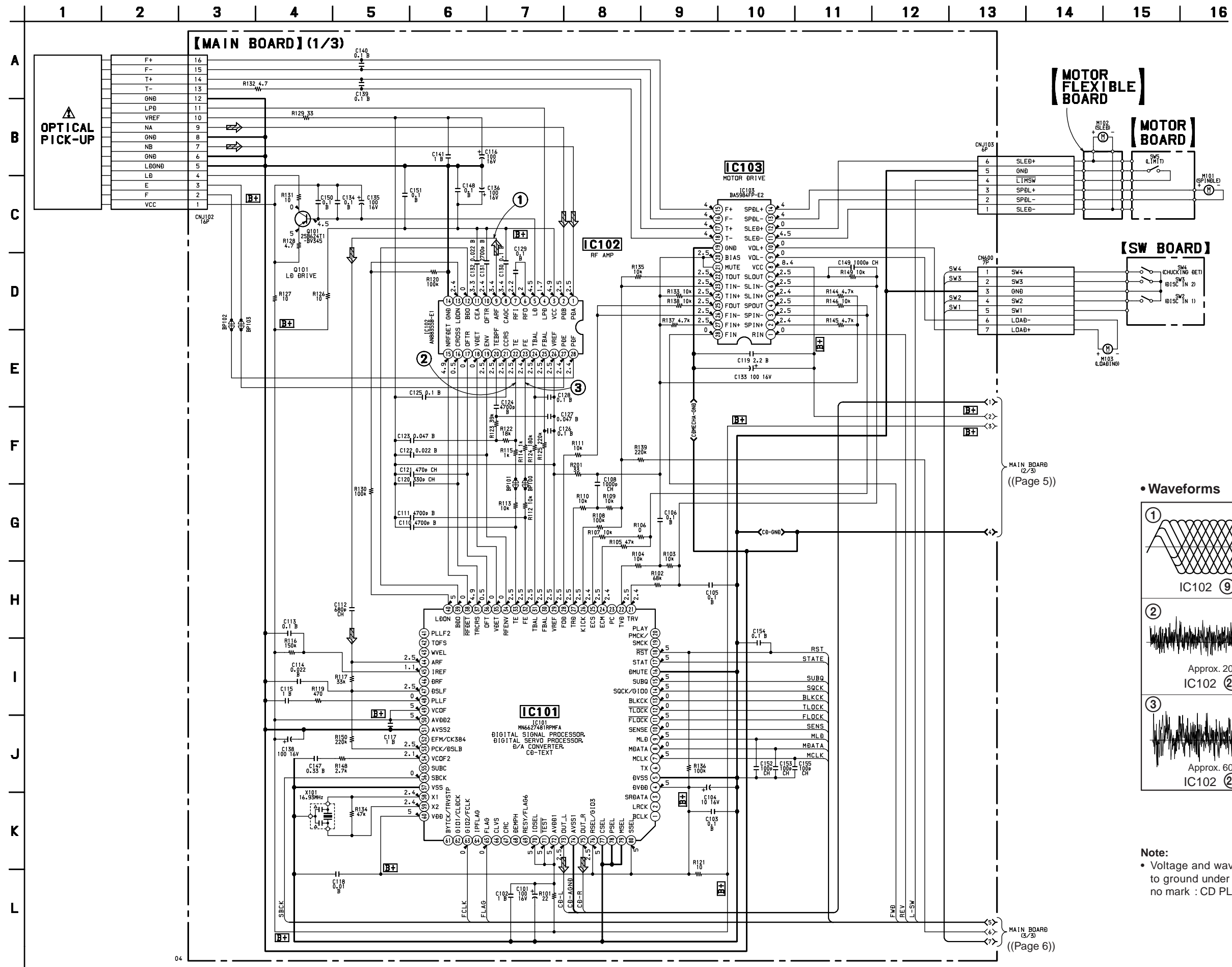

• Waveforms (MODE:PLAY)

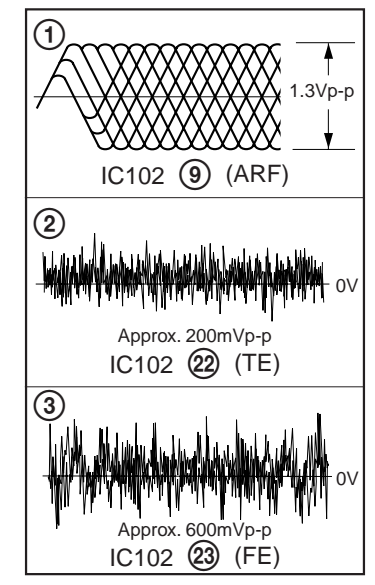

Note:

- Voltage and waveforms are dc with respect to ground under no-signal conditions.
- no mark : CD PLAY

3. SCHEMATIC DIAGRAM — MAIN SECTION (2/3) —

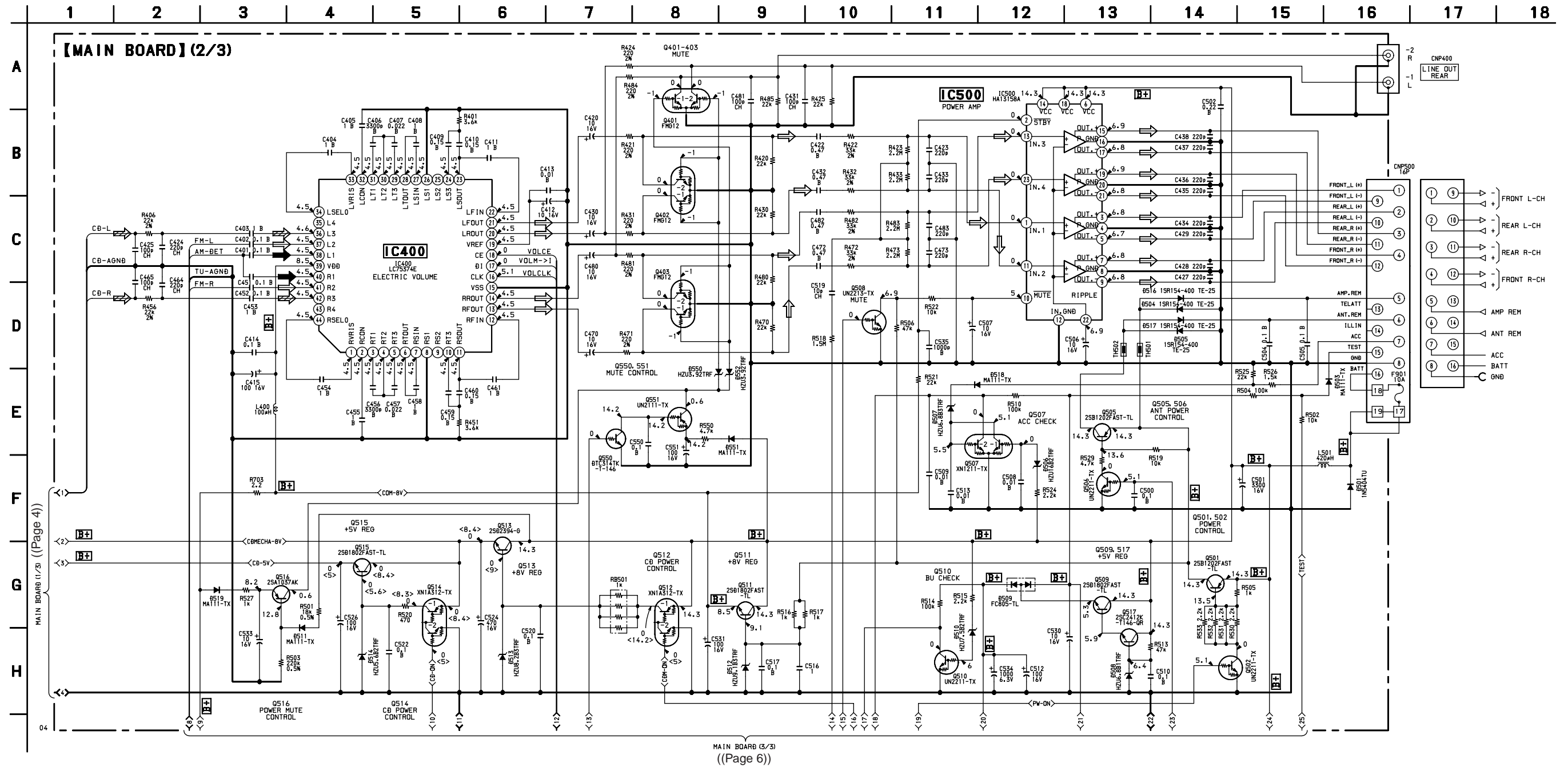

Note:
 • Voltage is dc with respect to ground under no-signal (detuned) condition.
 no mark : FM
 < > : CD PLAY

4. SCHEMATIC DIAGRAM — MAIN SECTION (3/3) —

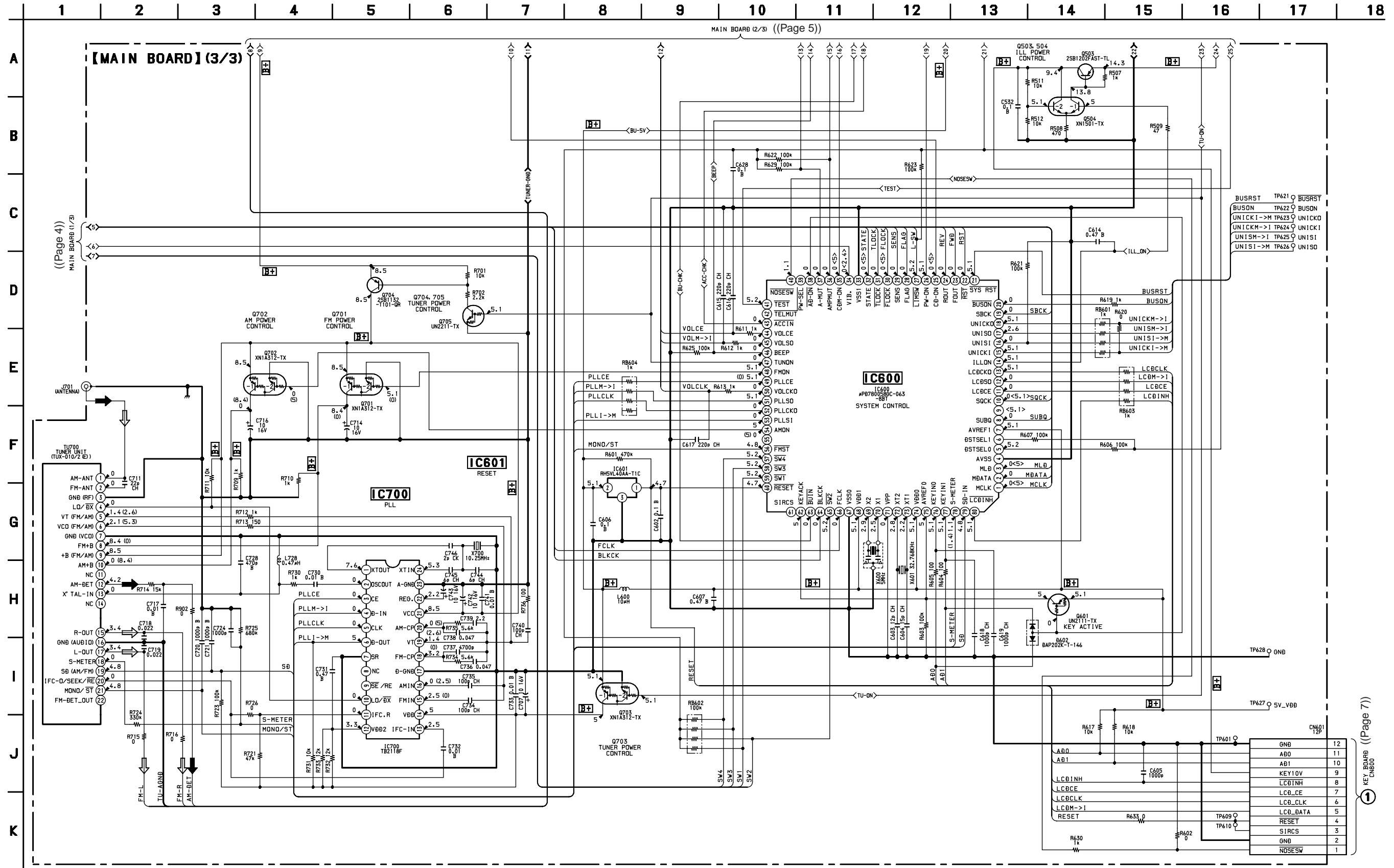

Note:

- Voltage is dc with respect to ground under no-signal (detuned) condition.
- no mark : FM
- () : AM
- < > : CD PLAY

5. SCHEMATIC DIAGRAM — DISPLAY SECTION —

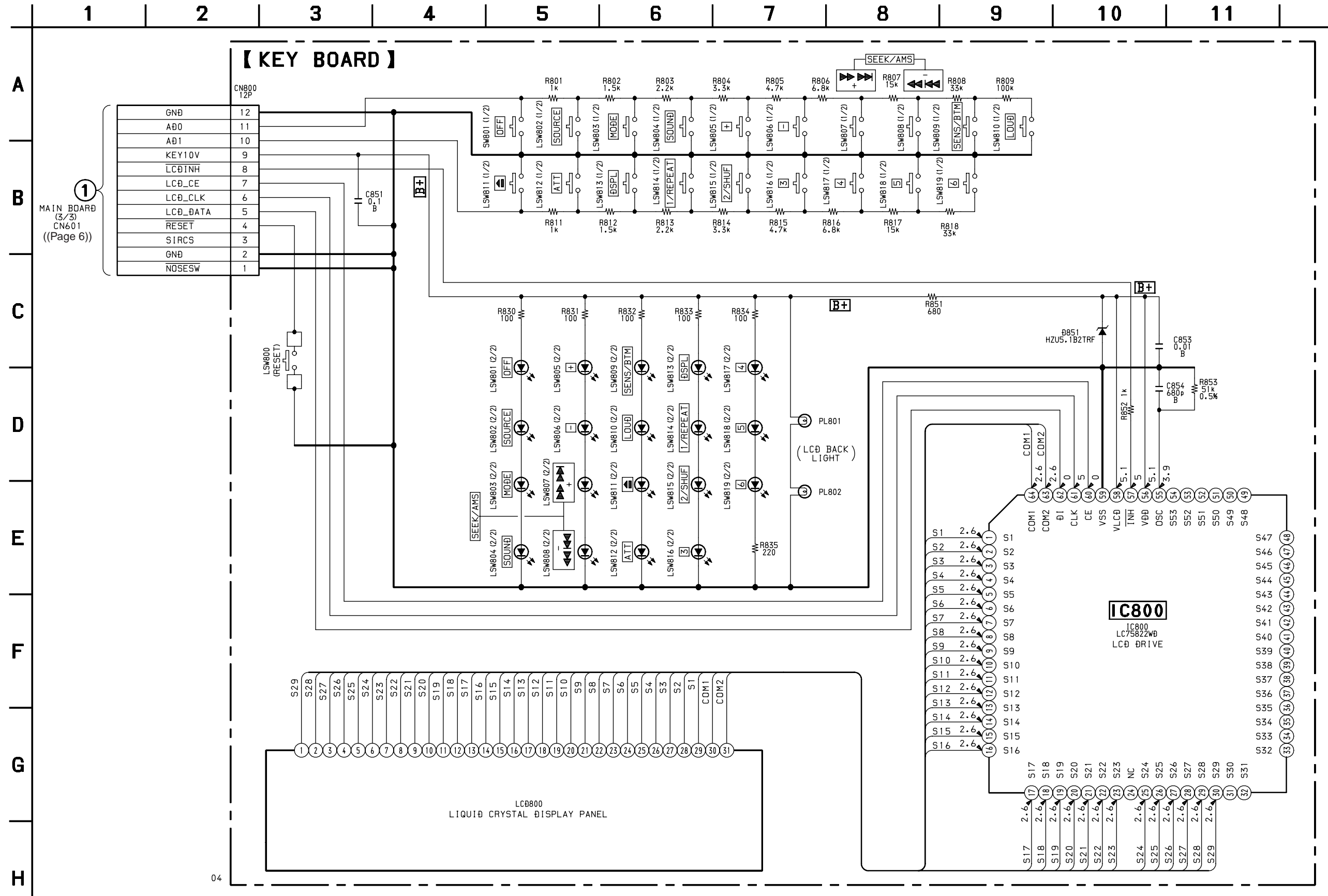

Note:

- Voltage is dc with respect to ground under no-signal (detuned) condition.
- no mark : FM